

MS Metal Pump Spectrogram

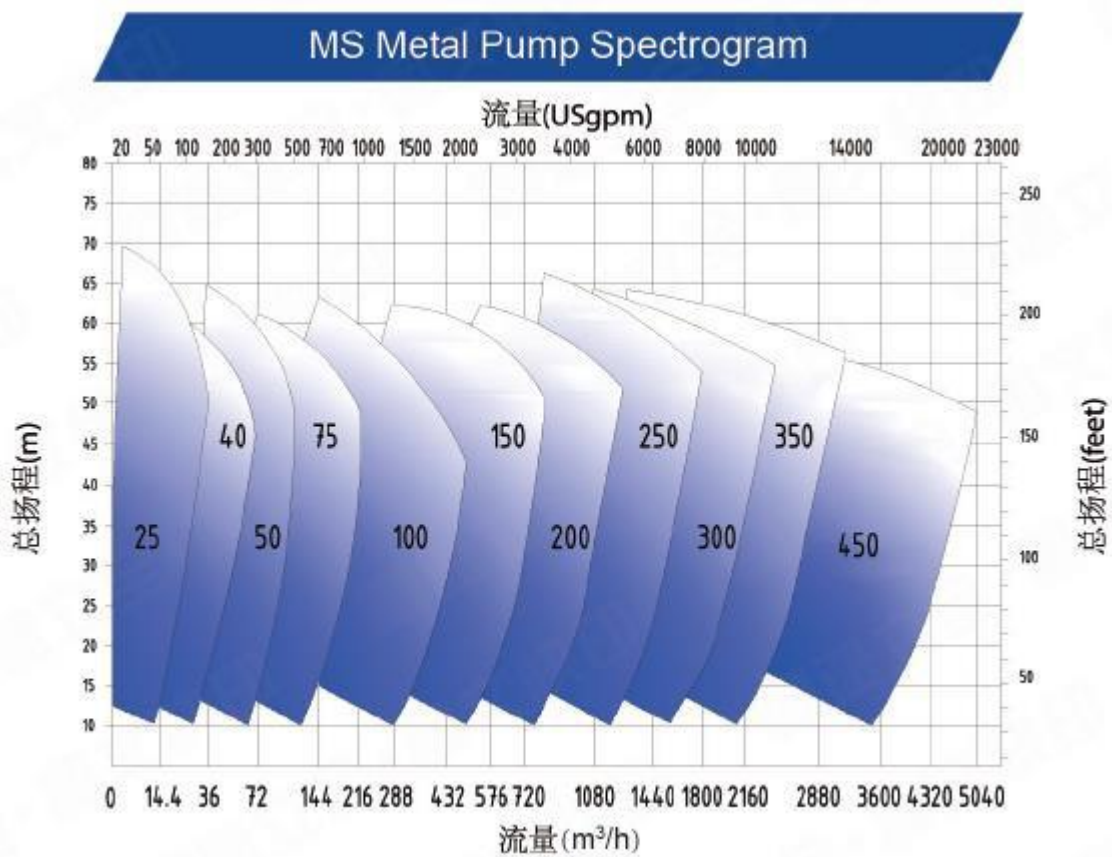

Technical Parameters

Pump Model	Flow Range (m³/hr)	Head range (m)	Speed (r/min)	NPSHr (mm)	Outlet diameter (mm)	Import diameter (mm)	Impeller diameter (mm)	Number of blades (pieces)	Bare pump weight (Kg)	Maximum shape of bare pump (mm)
100HKK-MS	100-400	10-70	800-1800	3-10	102	152	400	4	680	1024*698*768
100HL-MS	100-400	10-70	800-1800	3-10	102	152	400	4	780	1180*796*768
100HLL-MS	100-400	10-70	800-1800	3-10	102	152	400	4	800	1180*796*768
150HM-MS	200-800	10-80	500-1200	3-10	152	203	560	4	2200	1504*1142*1144
200HM-MS	500-1500	10-80	400-1000	3-10	203	254	750	4	3500	1640*1382*1320
300HNN-MS	1000-2500	10-80	300-700	3-10	305	356	1024	4	7200	2027*1886*1808

New type slurry pump advantages:

- 1.The efficiency of the new pump is increased by 6-8% compared with the original pump.
- 2.Easier installation, tighter fit of frame plate and cover plate, more accurate interface size at the outlet.
- 3.Improve the ease of installation and positioning accuracy of the volute, to avoid leakage caused by the displacement of the volute.
- 4.Increase the overall pressure-bearing capacity of the pump and extend the service life of the wet end parts.
- 5.Improve the ease of volute installation, more accurate positioning, and reduce displacement. By increasing the positioning of the volute outlet and reducing the overall force range, to improve the service life of the volute.
- 6.The throatbush and volute fit more reasonably and improve the sealing.



150 HMS

Horizontal Pump

Pump	
Discharge	152mm
Suction	203mm
Impeller	
Vane ø	560mm
Type	Closed
Vanes	5
Part No.	HM150001
Material	Metal
Frame (Rating - KW)	
L	120
LL	225
M	260
Q	300
MMX	425
MM	425
U	560
UX	560
Seal	
Gland Sealed Pump	
Liner (Norm Max r/min)	
Metal	1250
Min Passage Size	
70mm	
Curve	
Revision	1

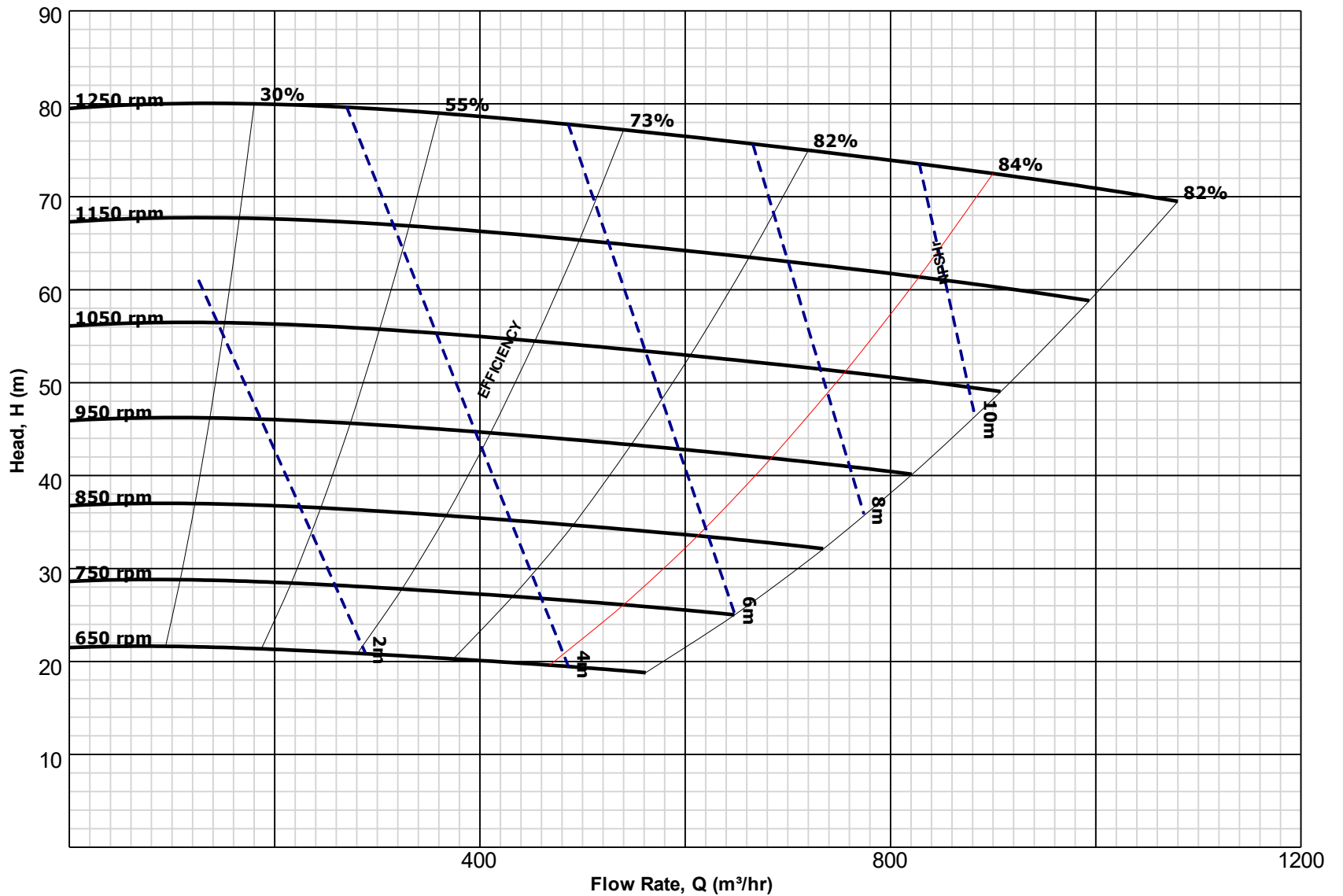

TYPICAL PUMP PERFORMANCE CURVE
WPAH150A01/1

© 11/2023 Metslurry
 All Rights Reserved

CURVE SHOWS APPROXIMATE PERFORMANCE FOR CLEAR WATER (International Test Standard ISO9906:1999 - Grade 2 unless otherwise specified). For media other than water, corrections must be made for density, viscosity and/or other effects of solids. Frame suitability must be checked for each duty and drive arrangement. Not all frame alternatives are necessarily available from each manufacturing centre. Metslurry reserves the right to change pump performance and/or delete impellers without notice.

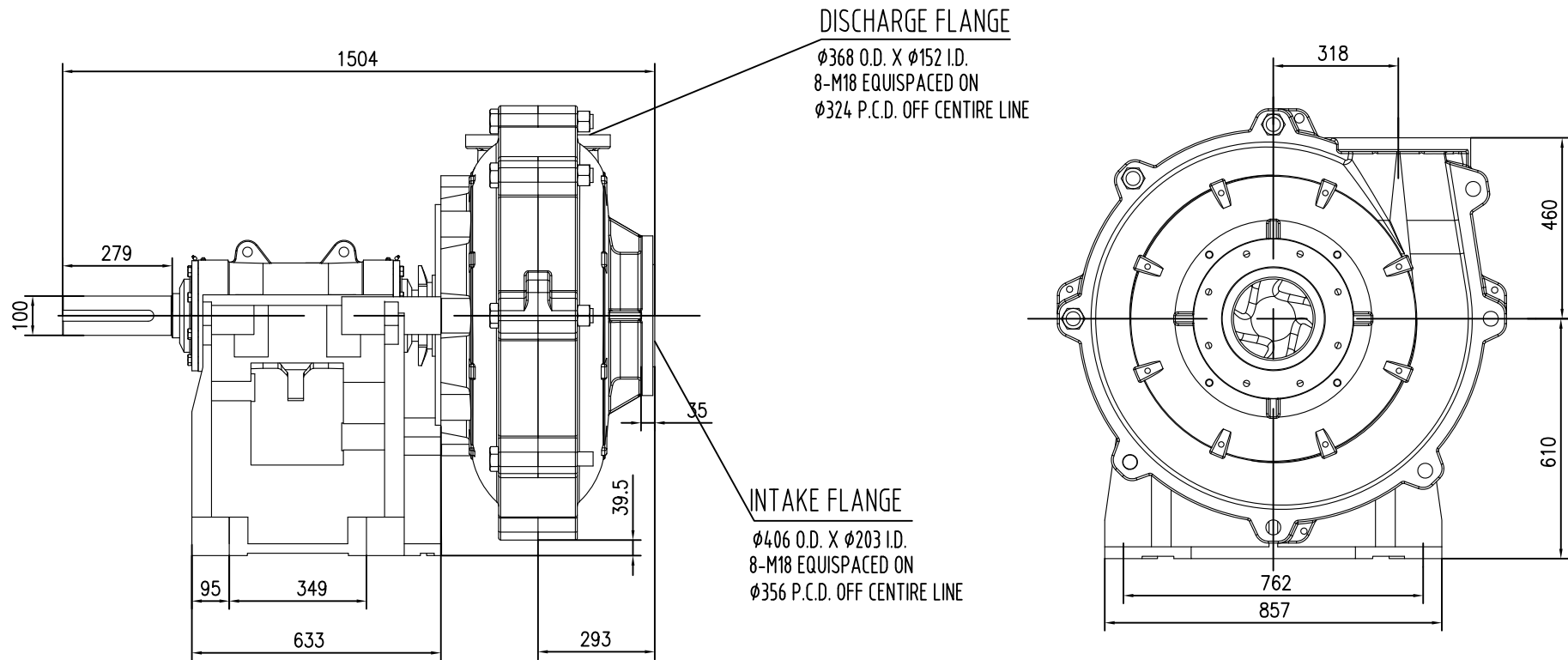

TECHNICAL REQUIREMENT

- 1.The pump rotates counterclockwise when viewed from the inlet
- 2.The outlet direction of the pump can be rotated at different positions at an interval of 30 degrees.

				SLURRY PUMP OUTLINE DIMENSIONS		150HM-MS		
						Weight	Proportion	REV
APROV	ZHAO	DATA	11.02.2022	2000	1:4	1		
VISTO	ZHANG			Shijiazhuang Mets Machinery Co. Ltd				
DES	ZHANG							